

K1250 Active K1250 RAIL

Reservdelar

Spare parts

Ersatzteile

Pieces de rechange

Piezas de repuesto

Ricambi

Peças sobresselente

A K1250
K1250 Rail

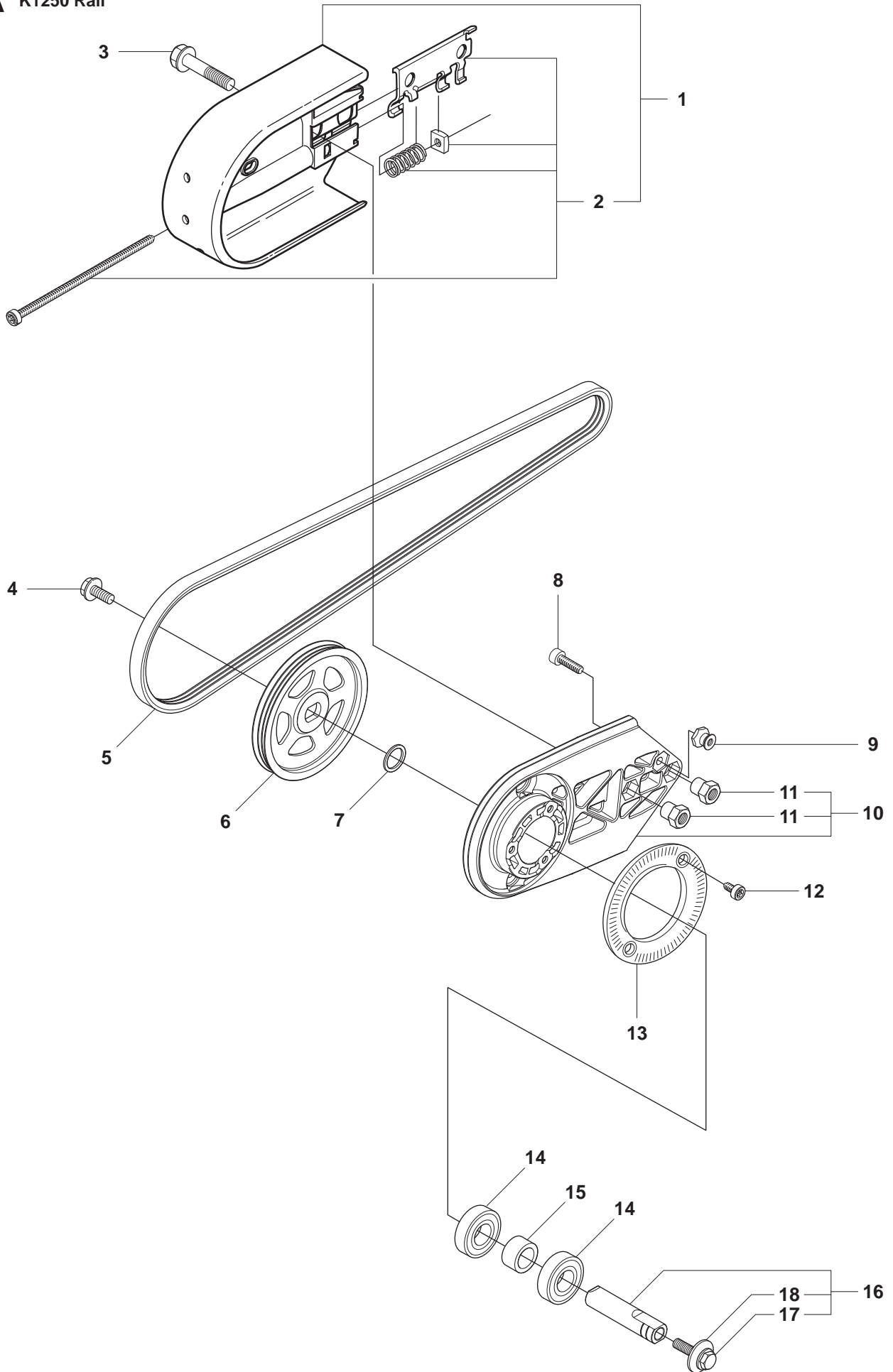

Page A
K1250, K1250 Rail

Pos.	Part No.	Description	Quantity	Notes	New Part
1	506 27 92-02	BELT GUARD	1	Incl. 2	
2	506 26 66-03	BELT TENSIONER ASSY	1		
3	506 28 44-01	COLLAR SCREW	2		
4	503 20 00-45	SCREW COLLAR	1		
5	544 97 63-01	BELT	1		New Part
5	506 37 27-21	BELT	1	Rail 14"	
5	506 37 27-28	BELT	1	Rail 16"	
6	544 98 50-01	PULLEY	1		New Part
6	506 07 18-02	PULLEY	2	Rail	
7	503 23 01-04	WASHER STEEL	1		
8	725 53 29-55	SCREW	1		
9	506 14 32-01	TORSION STOP	1		
10	506 39 42-06	BEARING HOUSING	1	Incl. 11	New Part
11	506 28 73-01	NUT	2		
12	503 20 07-12	SCREW	2		
13	506 28 84-01	SCREEN PATTERN FLANG	1		
14	503 25 21-01	BALL BEARING	2		
15	506 07 08-01	SPACING SLEEVE	1		
16	506 29 83-63	SHAFT	1	Incl. 17, 18	
17	506 13 96-01	COLLAR SCREW	1		
18	506 13 95-11	WASHER	1		

B K1250
K1250 Rail

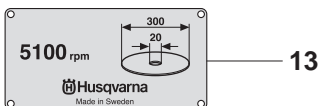
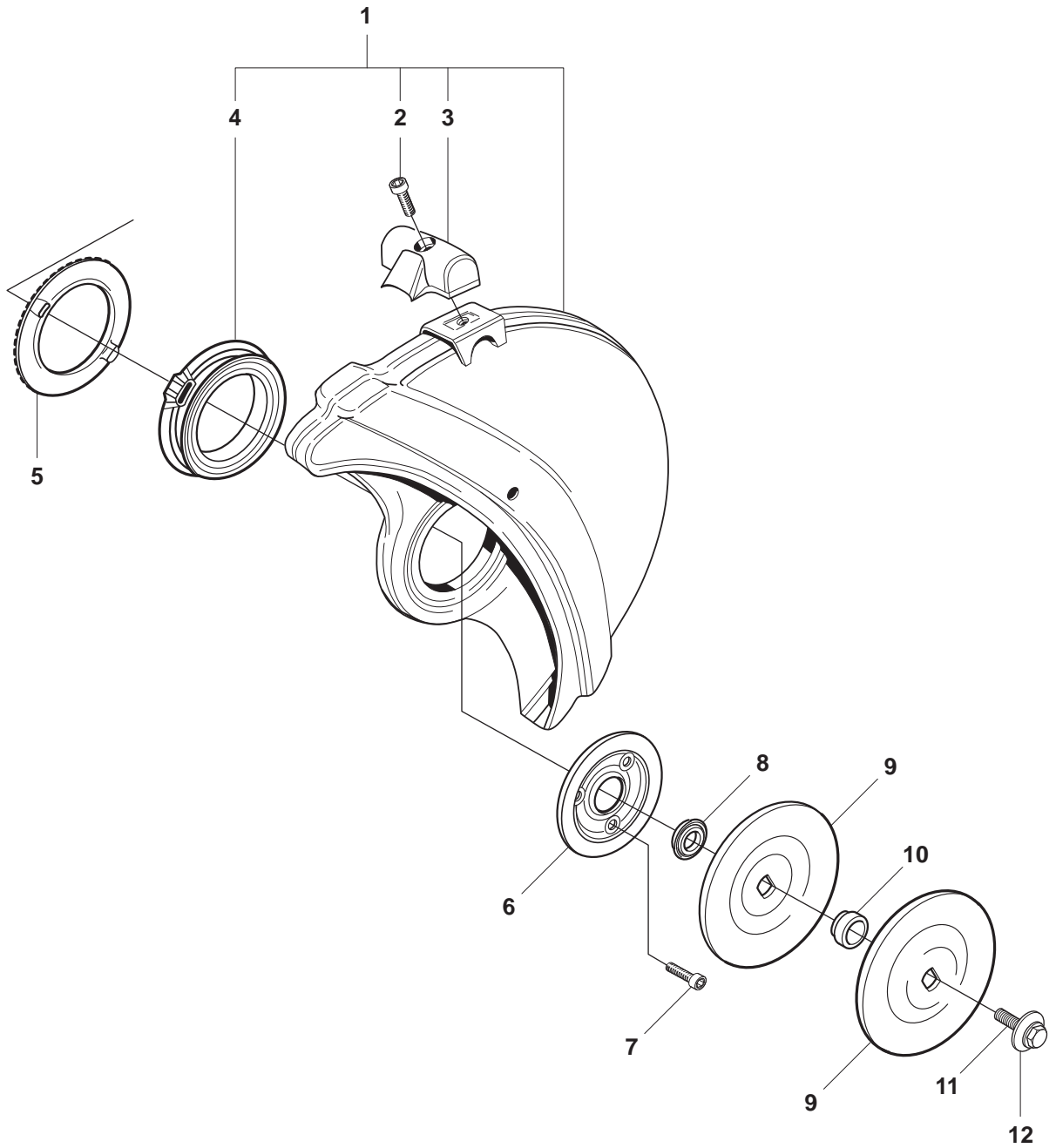

Page B**K1250, K1250 Rail**

Pos.	Part No.	Description	Quantity	Notes	New Part
1	506 34 05-04	WHEEL GUARD ASSY	1	14"	
1	506 34 05-06	WHEEL GUARD ASSY	1	16"	
1	506 34 05-24	WHEEL GUARD ASSY	1	Rail 14"	
1	506 34 05-26	WHEEL GUARD ASSY	1	Rail 16"	
2	725 53 31-55	SCREW	1		
3	506 34 46-02	HANDLE	1		
4	506 26 63-02	LINING	1		
5	506 26 64-01	SCREEN PATTERN FLANG	1		
6	506 26 65-01	FLANGE	1		
7	725 53 29-55	SCREW	3		
8	506 32 48-01	SUPPORT FLANGE	1	K1250 A	
8	506 26 71-01	SUPPORT FLANGE	1	K1250 Rail	
9	506 02 87-01	FLANGE WASHER	1	Diam 105 mm	
9	506 07 09-01	WASHER	1	Diam 119 mm	
10	506 37 96-20	BUSHING	1	Diam 20 mm	
10	506 37 96-22	BUSHING	1	Diam 22,2 mm	
10	506 37 96-25	BUSHING	1	Diam 25 mm	
10	506 02 88-30	BUSHING	1	Diam 30,5 mm	
11	506 13 95-11	WASHER	1		
12	506 13 96-01	COLLAR SCREW	1		
13	506 28 41-12	LABEL	1	14". Diam 20mm	
13	506 28 41-11	LABEL	1	14". Diam 22,2 mm	
13	506 28 41-14	LABEL	1	14". Diam 25,4mm	
13	506 28 41-22	LABEL	1	16". Diam 20mm	
13	506 28 41-21	LABEL	1	16". Diam 22,2mm	
13	506 28 41-24	LABEL	1	16". Diam 25,4mm	

C K1250
K1250 Rail

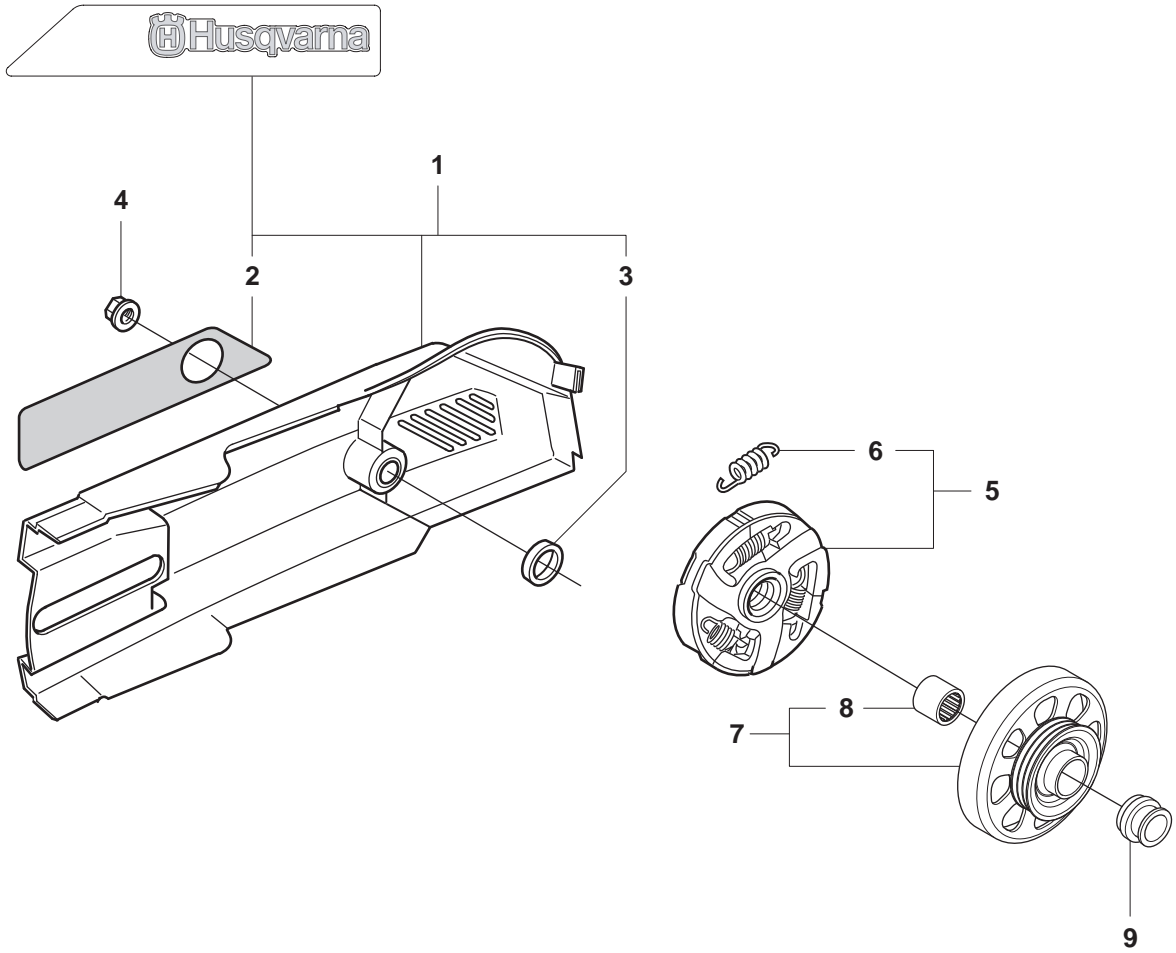

Page C**K1250, K1250 Rail**

Pos.	Part No.	Description	Quantity	Notes	New Part
1	506 27 17-03	BELT GUARD	1	Incl. 2, 3	
2	544 87 36-01	LABEL	1		
3	506 26 84-01	SPACING SLEEVE	1		
4	503 22 00-01	NUT FLANGE	1		
5	503 14 49-01	CLUTCH ASSY	1	Incl. 6	
6	503 14 51-01	CLUTCH SPRING	3		
7	540 05 28-01	GEAR WHEEL ASSY	1	14". Incl. 8	New Part
7	540 05 28-03	GEAR WHEEL ASSY	1	16". Incl. 8	New Part
7	506 25 49-01	GEAR WHEEL ASSY	1	Rail 16". Incl. 8	
7	506 25 49-03	GEAR WHEEL ASSY	1	Rail 14". Incl. 8	
8	503 25 38-01	NEEDLE BEARING	1		
9	506 28 59-01	SPACING SLEEVE	1		

D K1250
K1250 Rail

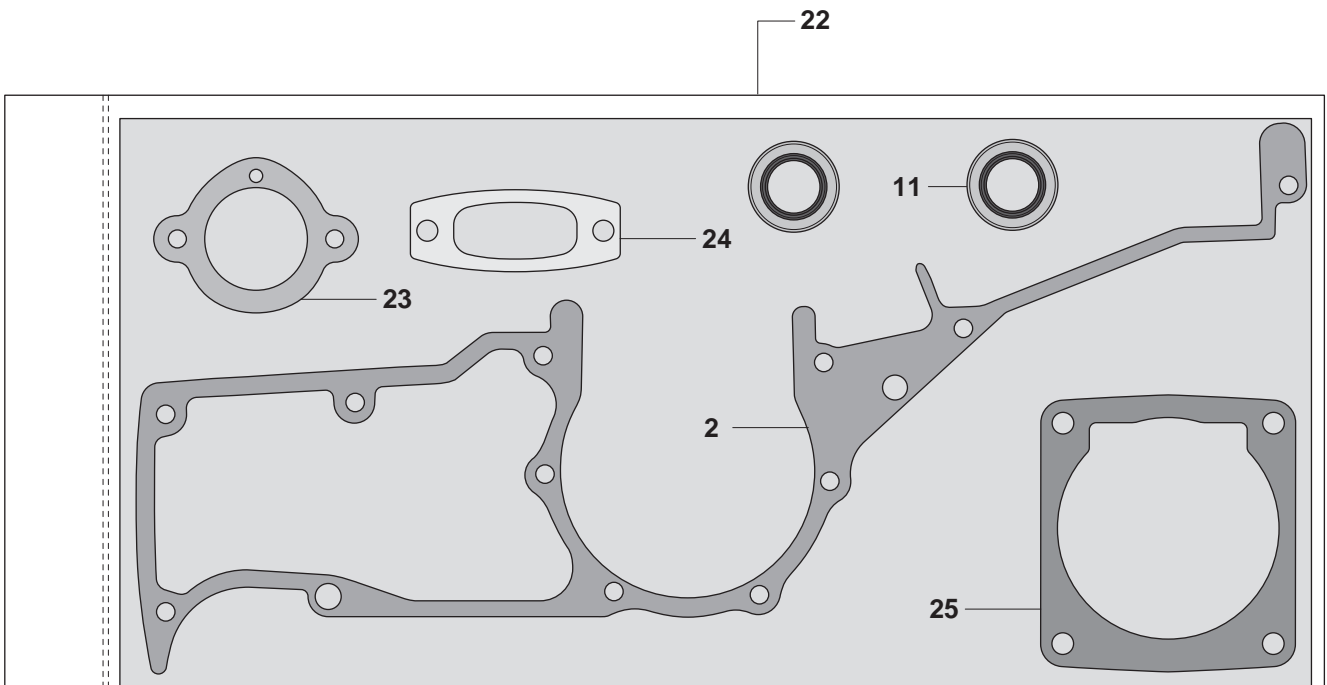
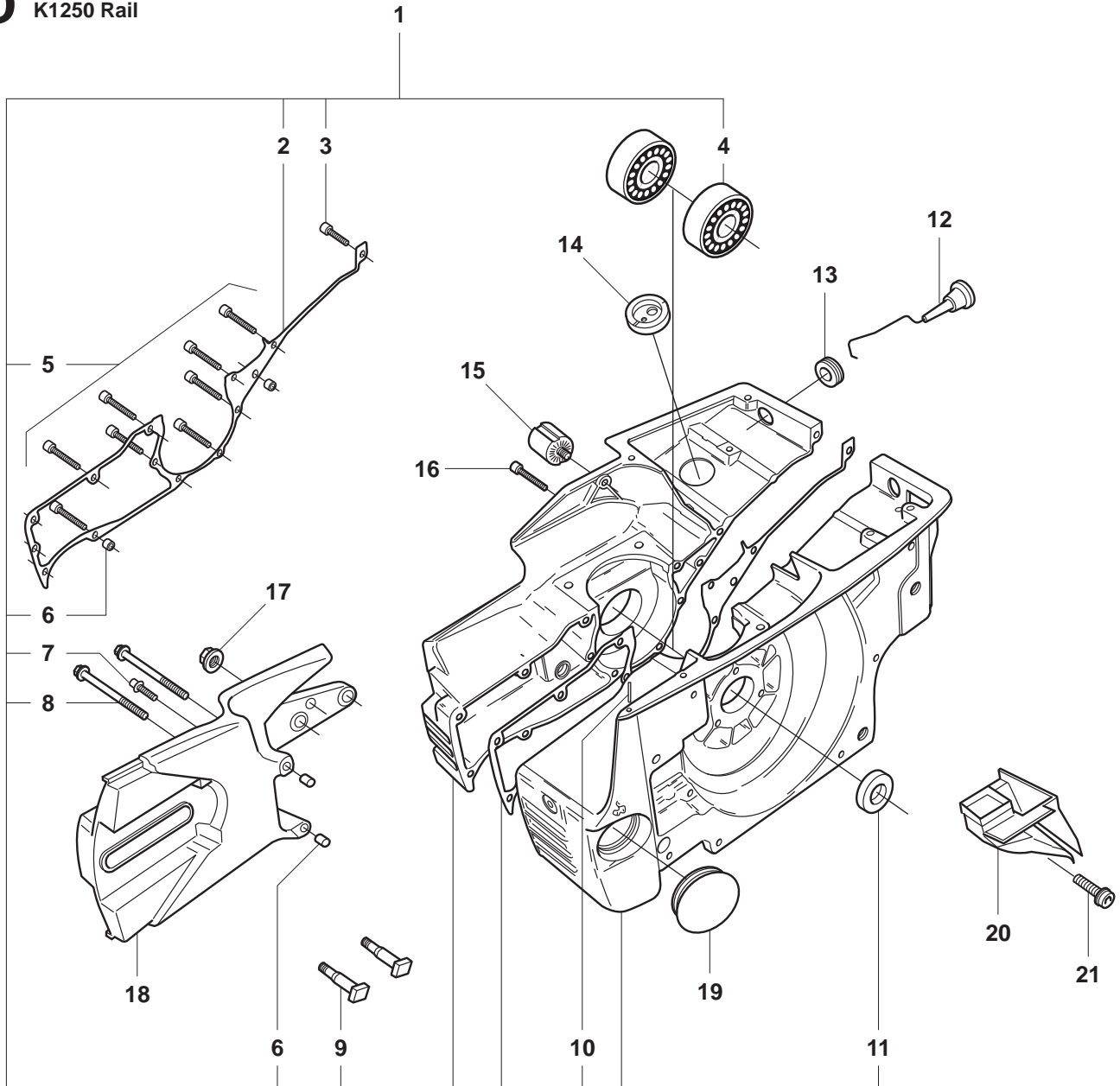

Page D**K1250, K1250 Rail**

Pos.	Part No.	Description	Quantity	Notes	New Part
1	501 89 25-72	CRANKCASE	1	Incl. 2-11	
2	503 13 45-01	CRANKCASE GASKET	1	Gasket kit 22	
3	725 53 31-55	SCREW	3		
4	503 25 00-02	BALL BEARING	2		
5	725 53 39-55	SCREW	9		
6	501 27 08-01	GUIDE BUSHING	4		
7	503 20 02-20	SCREW	1		
8	503 20 02-65	SCREW	2		
9	501 81 57-01	BAR BOLT	2		
10	721 42 06-00	PIN	1		
11	503 26 02-05	SEALING RING	2	Gasket kit 22	
12	506 25 43-01	CHOKE CONTROL	1		
13	503 14 54-02	GROMMET	1		
14	503 13 20-01	GROMMET	1		
15	501 26 97-04	VIB.INSULATOR	1		
16	725 53 70-55	SCREW	1		
17	503 22 00-01	NUT FLANGE	1		
18	506 24 14-02	CUTTER ARM	1		
19	506 26 97-02	PLUG	1		
20	506 23 70-01	AIR NOZZLE	1		
21	503 20 02-12	SCREW	1		
22	506 29 24-02	GASKET KIT	1		
23	506 27 43-01	GASKET	1		
24	503 13 13-04	GASKET MUFFLER	1		
25	503 13 46-01	GASKET	1		

E K1250
K1250 Rail

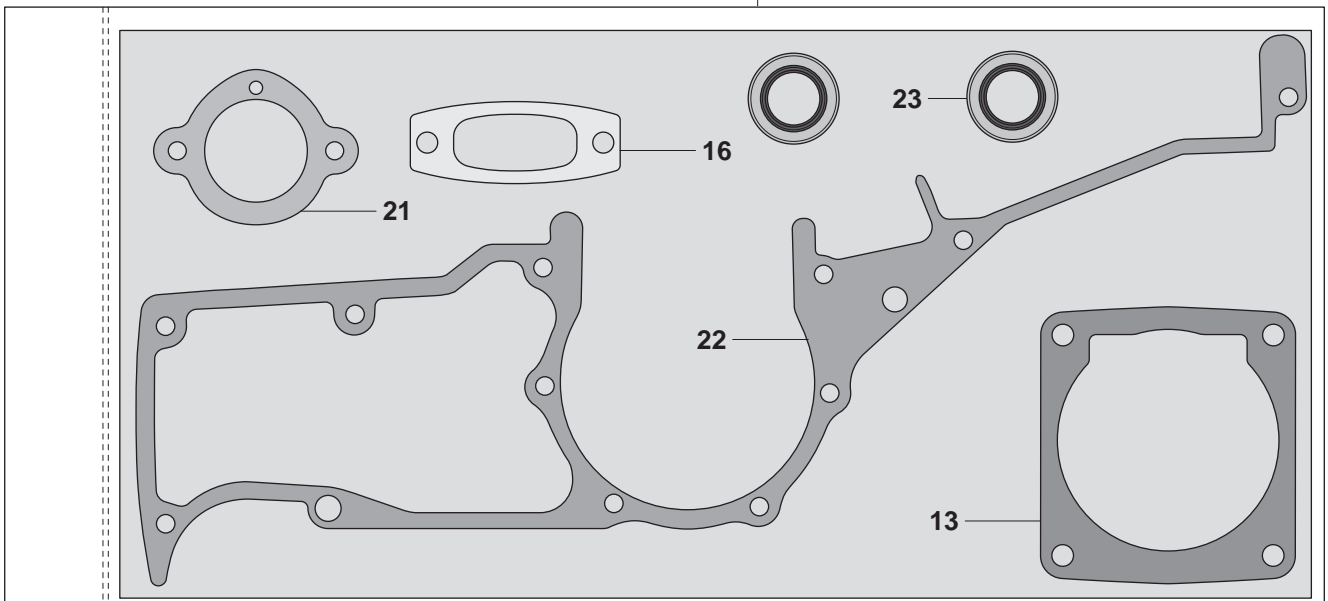
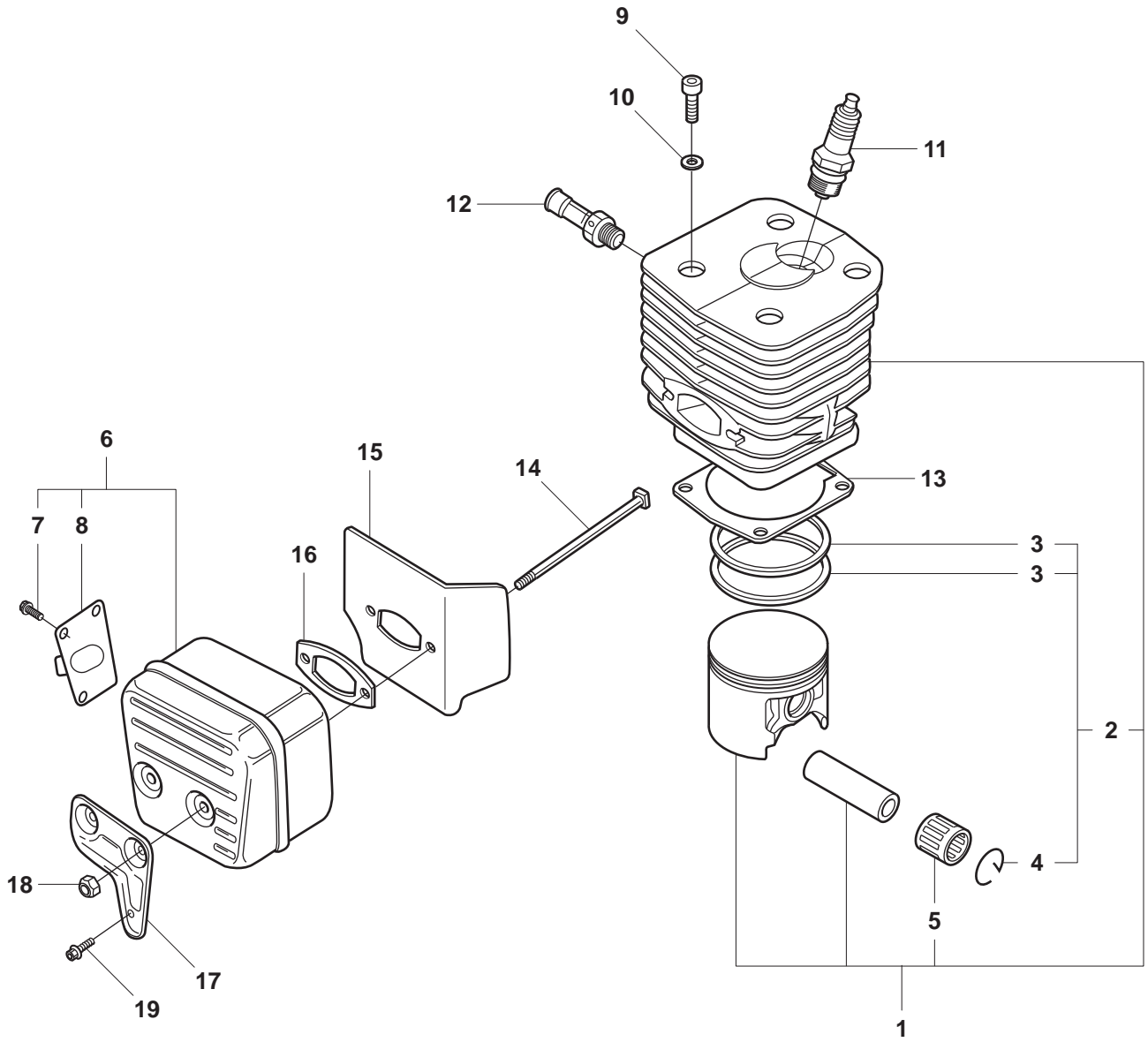

Page E
K1250, K1250 Rail

Pos.	Part No.	Description	Quantity	Notes	New Part
1	506 29 42-71	CYLINDER	1	Incl. 2, 3, 4, 5	
2	501 89 41-03	PISTON CPL	1	Incl. 3, 4,	
3	503 28 90-26	PISTON RING	2		
4	737 44 13-00	CIRCLIP	2		
5	503 13 29-01	SUPPORT BUSHING	1		
6	503 13 00-04	MUFFLER	1	Incl. 7, 8	
7	729 53 40-01	SCREW	4		
8	506 27 49-01	EXHAUST DUCT	1		
9	503 21 60-25	SCREW	4		
10	503 23 00-05	WASHER STEEL	4		
11	503 23 51-09	SPARK PLUG	1	RCJ 6Y	
12	503 66 56-01	DECOMPRESSION VALVE	1		
13	503 13 46-01	GASKET	1	Gasket kit 20	
14	503 21 64-01	SCREW	2		
15	506 34 14-01	COOLING PLATE	1		
16	503 13 13-04	GASKET MUFFLER	1	Gasket kit 20	
17	506 27 87-01	MUFFLER SUPPORT	1		
18	503 22 20-07	LOCK NUT	2		
19	725 53 68-55	SCREW	1		
20	506 29 24-02	GASKET KIT	1		
21	506 27 43-01	GASKET	1		
22	503 13 45-01	CRANKCASE GASKET	1		
23	503 26 02-05	SEALING RING	2		

F K1250
K1250 Rail

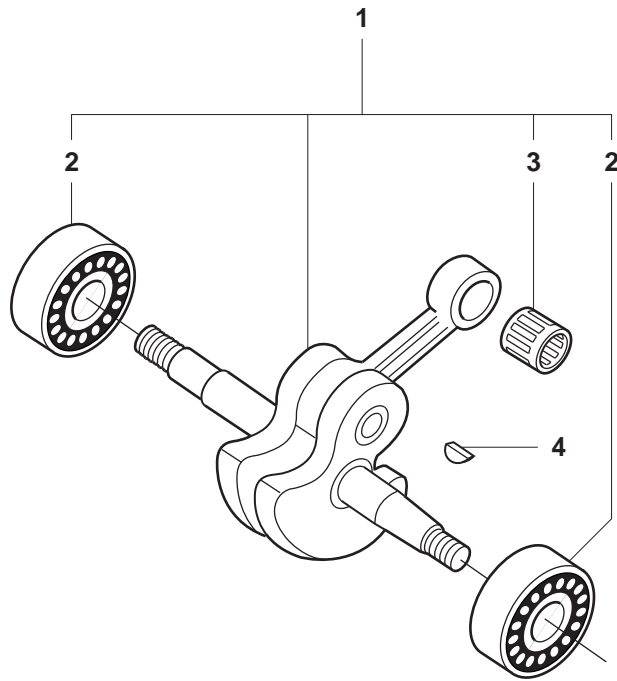

Page F
K1250, K1250 Rail

Pos.	Part No.	Description	Quantity	Notes	New Part
1	503 14 20-73	CRANKSHAFT ASSY	1	Incl. 2, 3	
2	503 25 00-02	BALL BEARING	2		
3	503 13 29-01	SUPPORT BUSHING	1		
4	735 88 06-00	WOODRUFF KEY	1		

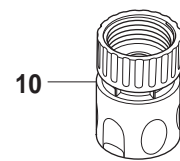
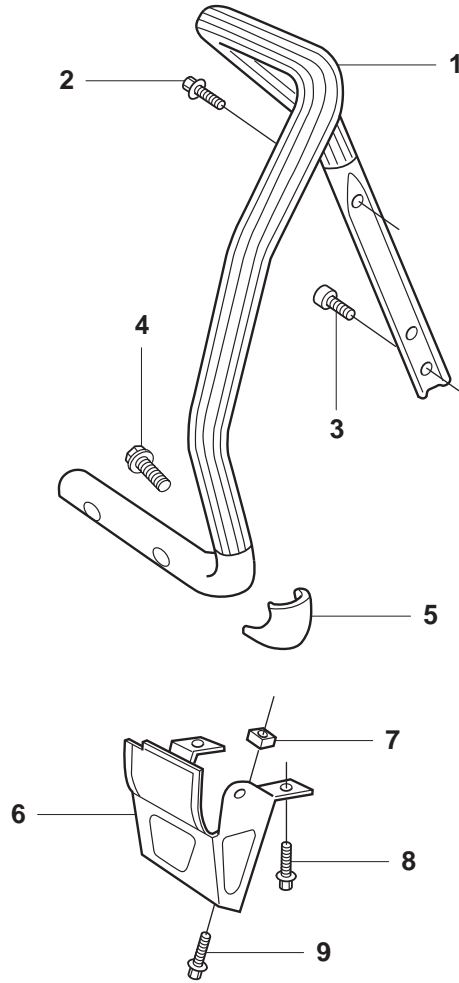

Page G**K1250, K1250 Rail**

Pos.	Part No.	Description	Quantity	Notes	New Part
1	506 25 53-02	HANDLE	1		
2	503 20 02-10	SCREW	1		
3	503 21 05-25	SCREW	2		
4	503 21 06-32	SCREW	4		
5	506 14 90-01	SUPPORT	1		
6	506 25 01-01	GROUND SUPPORT	1		
7	503 22 65-04	NUT	2		
8	725 53 70-55	SCREW	2		
9	503 20 03-12	SCREW	2		
10	503 26 60-02	COUPLER	1		

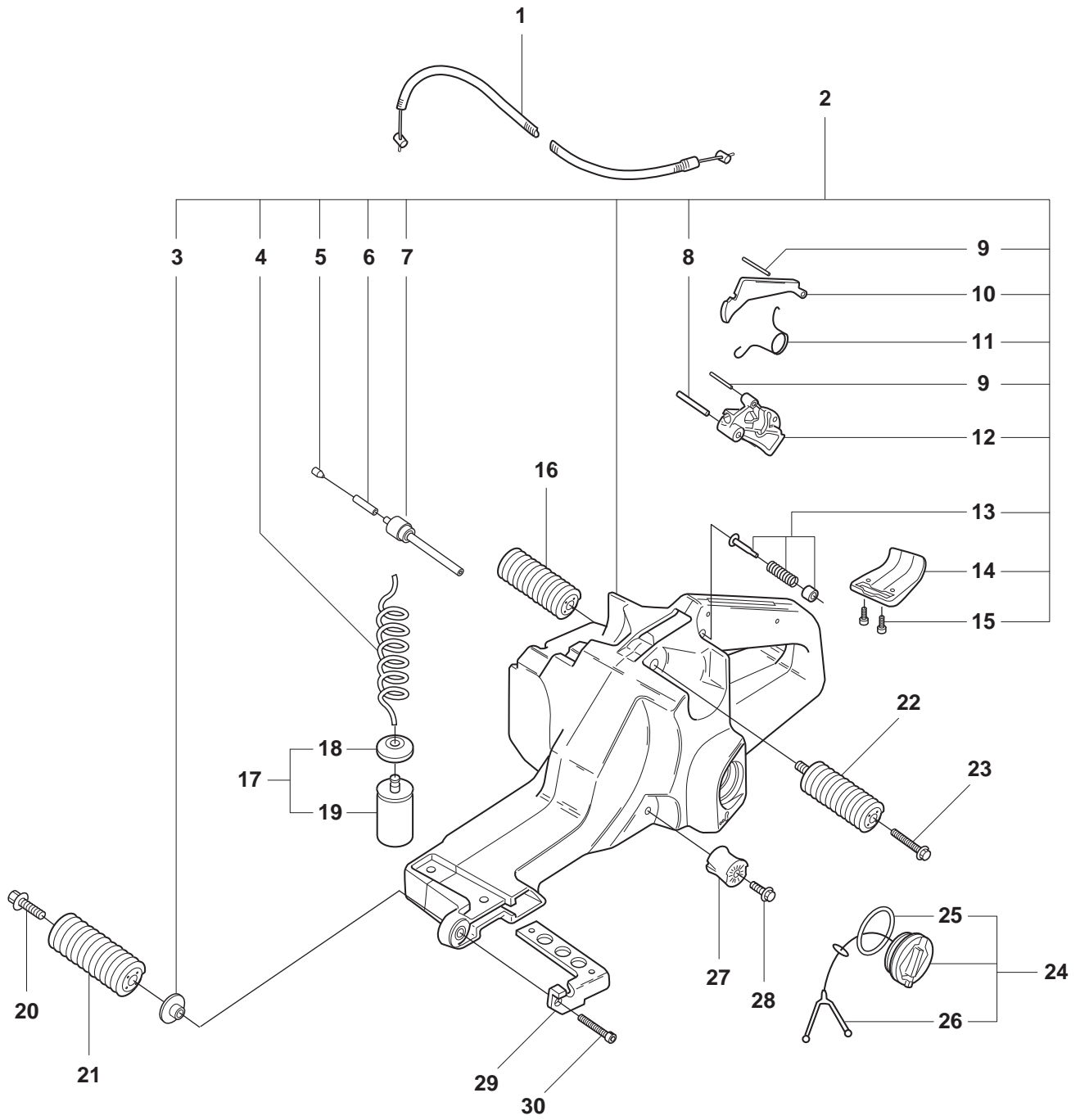

Page H
K1250, K1250 Rail

Pos.	Part No.	Description	Quantity	Notes	New Part
1	506 28 98-01	THROTTLE WIRE	1		
2	503 14 21-06	TANK UNIT ASSY	1	Incl. 3 - 15	
3	503 14 08-01	BUSHING	1		
4	503 57 76-02	FUEL HOSE	1		
5	504 35 72-01	SINTER PLUG	1		
6	501 76 83-04	FUEL HOSE	1		
7	506 29 39-01	TANK WENT	1		
8	720 12 78-06	PIN	1		
9	720 12 40-20	PARALLEL PIN	1		
10	503 13 16-01	THROTTLE LOCKOUT	1		
11	503 13 18-01	SPRING	1		
12	503 13 36-01	THROTTLE LEVER	1		
13	503 14 23-01	THROTTLE CATCH	1		
14	506 23 34-01	SUPPORT	1		
15	503 21 45-16	SCREW	2		
16	503 13 26-01	AV-ELEMENT	1		
17	506 26 41-11	FUEL FILTER	1	Incl. 18, 19	
18	506 27 11-01	HOSE CLAMP	1		
19	506 26 41-01	FUEL FILTER	1		
20	503 20 02-25	SCREW	1		
21	503 13 27-01	AV-ELEMENT	1		
22	503 13 25-01	AV-ELEMENT	1		
23	725 53 68-55	SCREW	2		
24	506 25 59-03	TANK CAP ASSY	1	Incl. 25, 26	
25	506 29 21-01	GASKET	1		
26	503 57 89-01	HOLDER	1		
27	501 81 47-01	ANTIVIBRATIONS ELEME	1		
28	503 20 02-12	SCREW	1		
29	503 14 05-01	STIFFENING PLATE	1		
30	503 20 02-30	SCREW	1		

J K1250
K1250 Rail

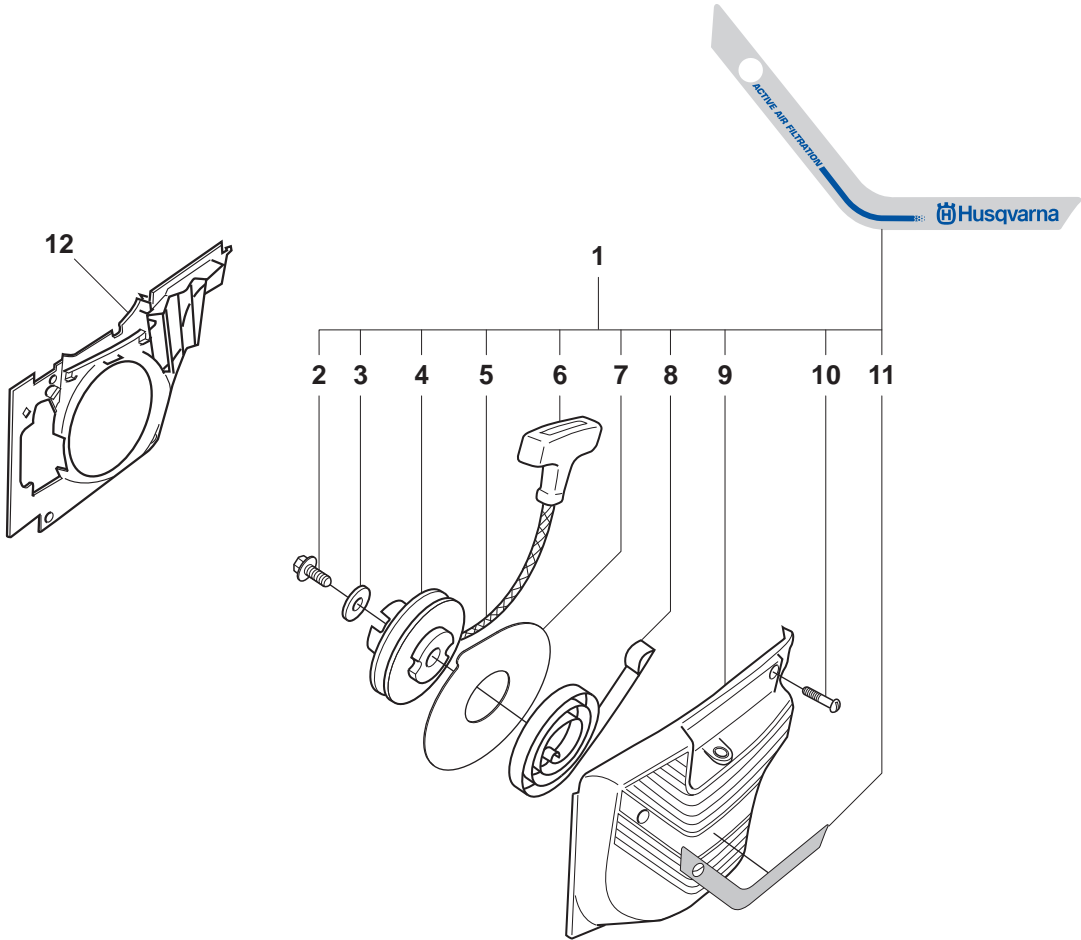

Page J
K1250, K1250 Rail

Pos.	Part No.	Description	Quantity	Notes	New Part
1	506 27 55-02	STARTER	1	Incl. 2-11	
2	503 21 06-16	SCREW	1		
3	503 23 43-02	WASHER	1		
4	501 89 67-01	STARTER PULLEY	1		
5	506 33 56-25	STARTER CORD	1		
6	503 12 79-01	STARTER HANDLE	1		
7	503 74 36-01	DISC	1		
8	503 13 50-01	RECOIL SPRING ASSY	1		
9	506 25 58-02	STARTER COVER	1		
10	503 20 34-25	SCREW	4		
11	544 87 35-01	LABEL	1		
12	501 89 59-02	AIR CONDUCTOR	1	K1250 A	
12	501 89 59-03	AIR CONDUCTOR	1	K1250 Rail	

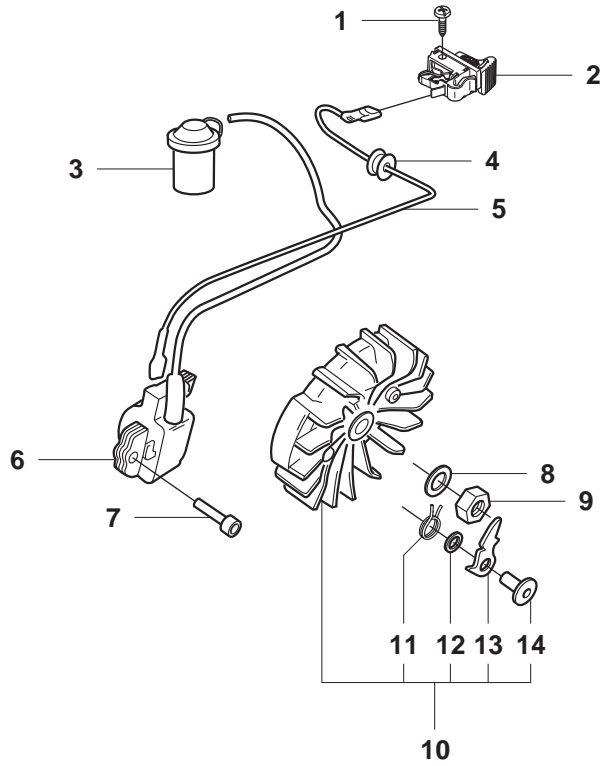

Page K
K1250, K1250 Rail

Pos.	Part No.	Description	Quantity	Notes	New Part
1	503 21 90-08	SCREW	1		
2	506 31 86-02	STOP SWITCH	1		
3	501 48 54-02	SPARK PLUG CAP	1		
4	503 13 24-01	CABLE GROMMET	1		
5	501 83 98-03	CABLE	1		
6	544 01 88-01	IGNITION SYSTEM	1		
7	503 20 25-20	SCREW	1		
8	735 11 73-50	SPRING WASHER	1		
9	503 22 10-03	NUT	1		
10	501 89 50-03	FLYWHEEL ASSY	1	Incl. 2-5	
11	501 63 48-01	SPRING	2		
12	503 23 00-42	WASHER STEEL	2		
13	501 67 32-03	PAWL	2		
14	501 81 99-01	SCREW	2		

L K1250
K1250 Rail

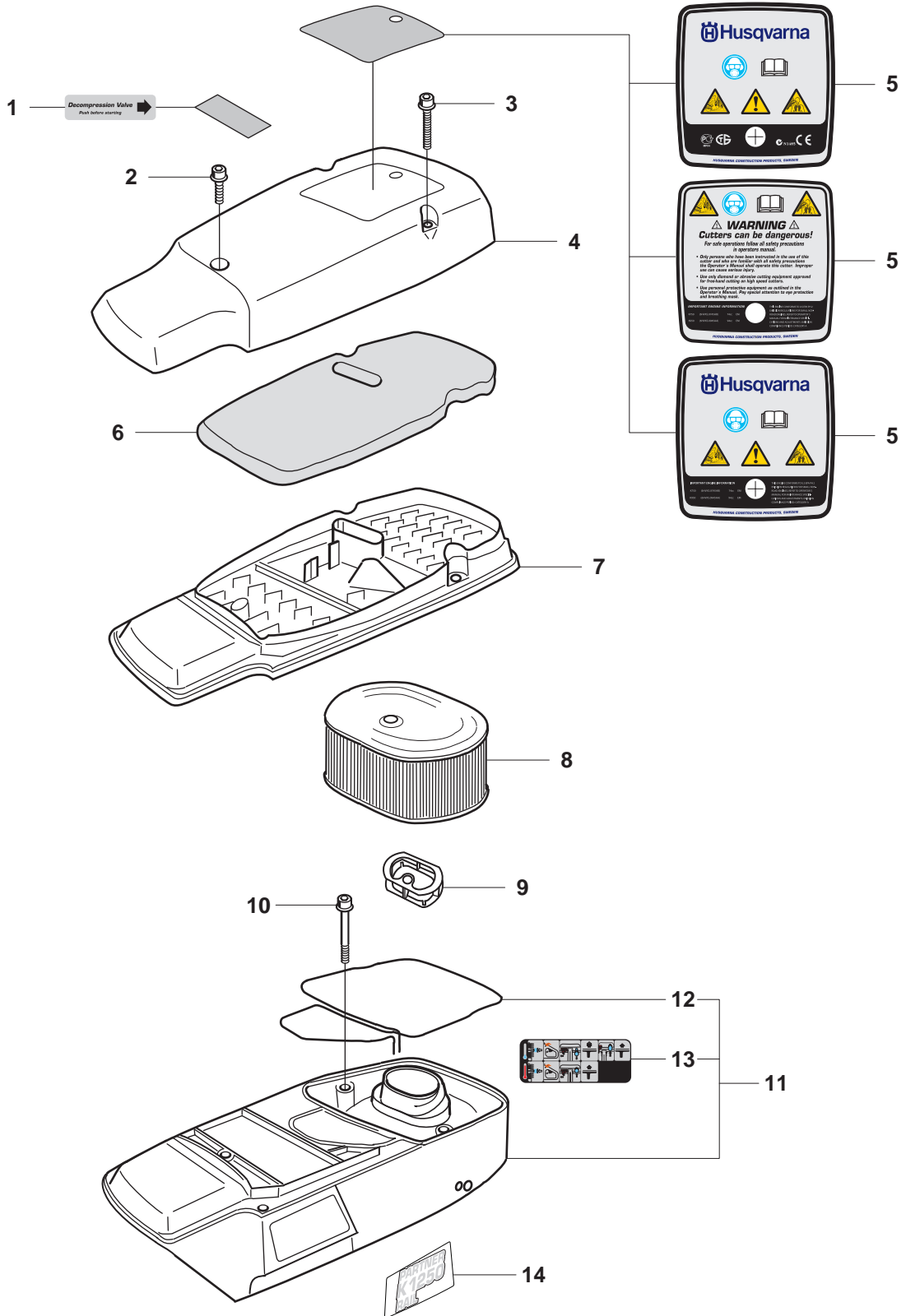

Page L
K1250, K1250 Rail

Pos.	Part No.	Description	Quantity	Notes	New Part
1	544 87 46-02	LABEL	1		
2	503 20 34-25	SCREW	1		
3	503 20 34-55	SCREW	2		
4	506 25 56-02	FILTER COVER	1		
5	544 87 44-02	LABEL	1	CE	
5	544 87 44-03	LABEL	1	EPA Canada	
5	544 87 44-04	LABEL	1	EPA USA	
6	506 26 87-01	PREFILTER	1		
7	506 25 57-02	FILTER BOTTOM	1		
8	506 23 18-03	AIR FILTER	1		
9	506 25 03-01	INSERT	1		
10	503 20 02-30	SCREW	4		
11	506 27 54-02	CYLINDER COVER	1	Incl. 2, 3, 4	
12	506 28 39-30	SEALING	1		
13	544 87 38-01	LABEL	1		
14	544 87 39-01	LABEL	1	K1250	
14	544 87 39-02	LABEL	1	K1250 Rail	

M K1250
K1250 Rail

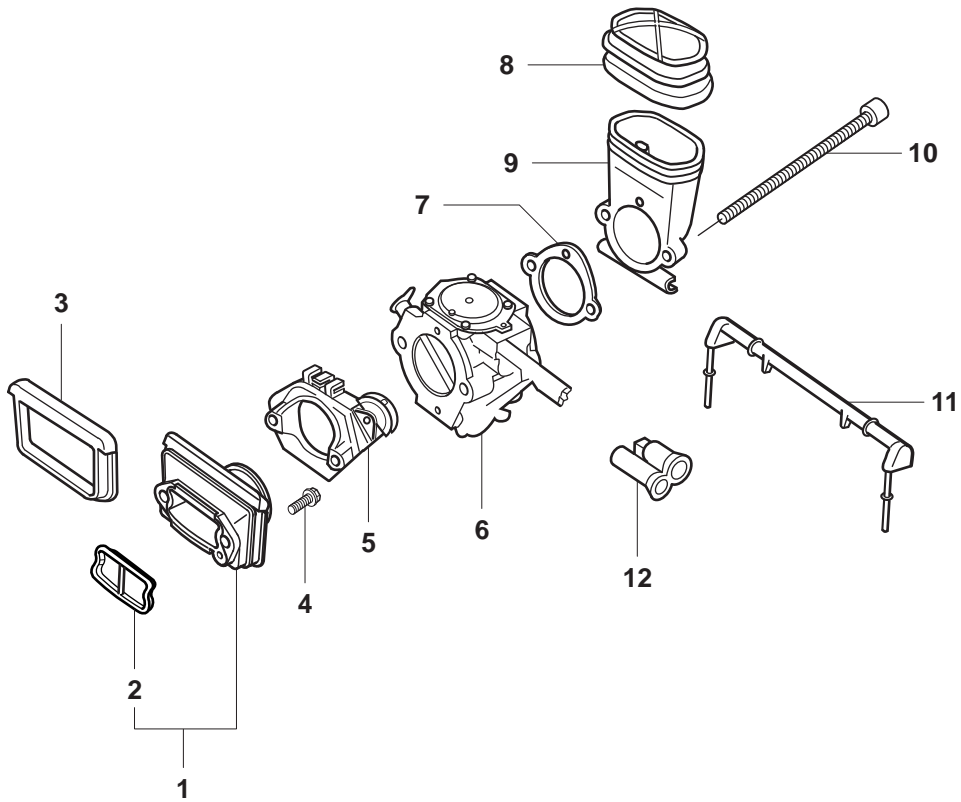

13

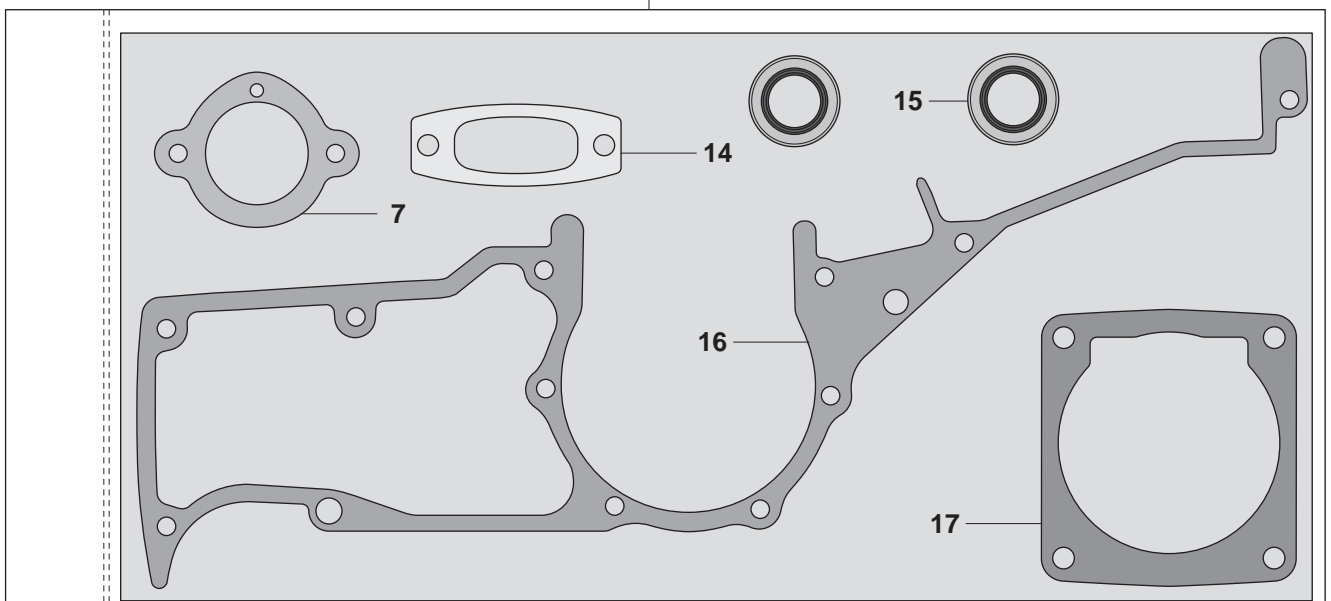

Page M
K1250, K1250 Rail

Pos.	Part No.	Description	Quantity	Notes	New Part
1	506 24 10-71	INLET PIPE	1	Incl. 2	
2	506 31 38-01	INSERT	1		
3	503 14 37-01	SEALING	1		
4	503 20 02-20	SCREW	1		
5	506 28 97-01	FLANGE	1		
6	503 28 12-17	CARBURETTOR	1		
7	506 27 43-01	GASKET	1	Gasket kit 13	
8	506 25 02-01	BELLOWS	1		
9	506 24 13-01	INLET BEND	1		
10	503 21 75-65	SCREW	2		
11	506 25 04-01	SUPPORT	1		
12	506 25 46-01	CHISEL GUIDE	1		
13	506 29 24-02	GASKET KIT	1		
14	503 13 13-04	GASKET MUFFLER	1		
15	503 26 02-05	SEALING RING	2		
16	503 13 45-01	CRANKCASE GASKET	1		
17	503 13 46-01	GASKET	1		

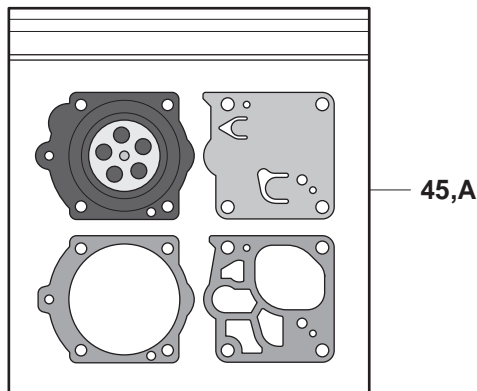
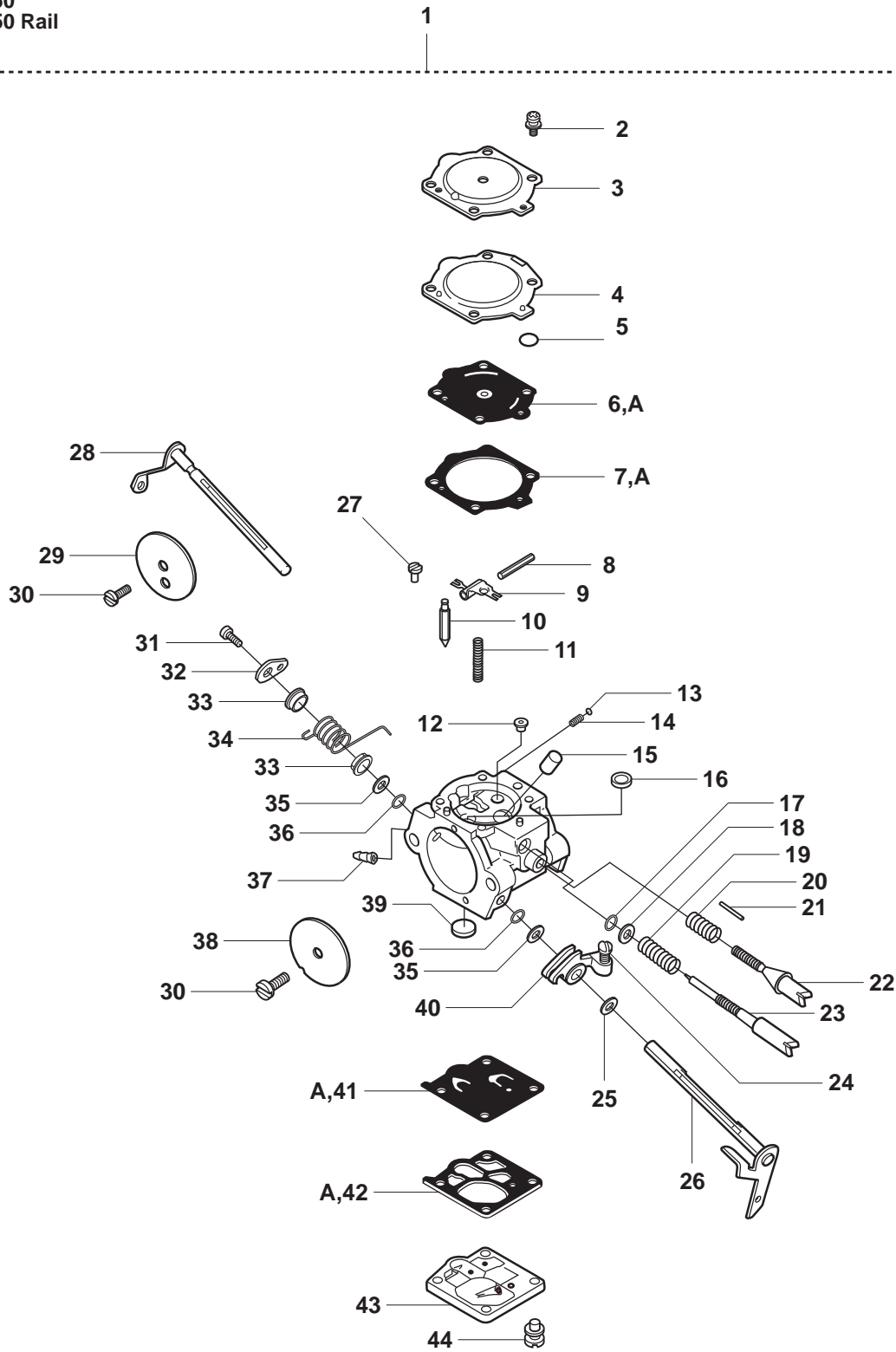

Page N
K1250, K1250 Rail

Pos.	Part No.	Description	Quantity	Notes	New Part
1	503 28 12-17	CARBURETTOR	1		
2	537 00 31-01	SCREW	1		
3	501 69 28-01	COVER-METERING DIAPH	1		
4	537 00 29-01	COVER	1		
5	537 00 28-01	RING	1		
6	503 63 28-01	DIAPHRAGM ASSY METER	1	Kit 45	
7	501 46 75-01	GASKET-METERING DIAP	1		
8	505 31 67-31	PIN-METERING LEVER	1		
9	505 31 67-34	LEVER-METERING	1		
10	503 56 34-01	VALVE INLET NEEDLE	1		
11	505 31 67-23	SPRING-METER.LEVER	1		
12	537 15 34-01	JET	1		
13	501 46 85-01	BALL-CHOKE FRICTION	1		
14	501 46 84-01	SPRING-CHOKE FRICT.	1		
15	503 97 66-01	NOZZLE ASSY	1		
16	503 57 42-01	PLUG-WELCH	1		
17	503 59 55-01	O-RING	1		
18	503 59 72-01	WASHER	1		
19	505 31 67-37	SPRING-NEEDLE	1		
20	503 63 31-01	SPRING	1		
21	503 52 60-01	PIN THROTTLE STOP	1		
22	503 63 29-01	SCREW IDLE SPEED	1		
23	503 63 32-01	NEEDLE IDLE SPEED	1		
24	503 59 65-01	SCREW	1		
25	506 02 83-01	WASHER	1		
26	503 59 59-01	SHAFT ASS'Y THROTTLE	1		
27	505 31 67-17	SCREW-LEVER PIN	1		
28	537 00 30-01	SHAFT ASS'Y	1		
29	503 52 58-01	VALVE CHOKE	1		
30	530 03 50-15	SCREW-VALVE	2		
31	503 19 22-01	SCREW PAN HD(M2.5x5)	1		New Part
32	503 59 56-01	LEVER THROTTLE	1		
33	502 10 31-01	BUSHING-THROTT.SPR.	2		
34	503 52 59-01	SPRING THROTT RETURN	1		
35	505 31 67-48	WASHER	2		
36	503 56 45-01	SEAL-THROTTLE SHAFT	2		
37	503 59 84-01	FITTING FUEL INLET	1		
38	503 63 24-01	VALVE THROTTLE	1		
39	501 66 61-01	SCREEN-INLET	1		
40	503 59 57-01	LEVER THROTTLE INNER	1		
41	503 11 73-01	DIAPHRAGM-PUMP	1	Kit 45	
42	503 11 72-01	GASKET-PUMP	1	Kit 45	
43	503 59 58-01	COVER-PUMP	1		
44	503 11 75-01	SCREW-PUMP COVER	1		
45	503 59 74-02	GASKET KIT	1		

P

K1250
K1250 Rail

Accessories
Zubehöre
Accessoires
Accesorios
Tillbehör

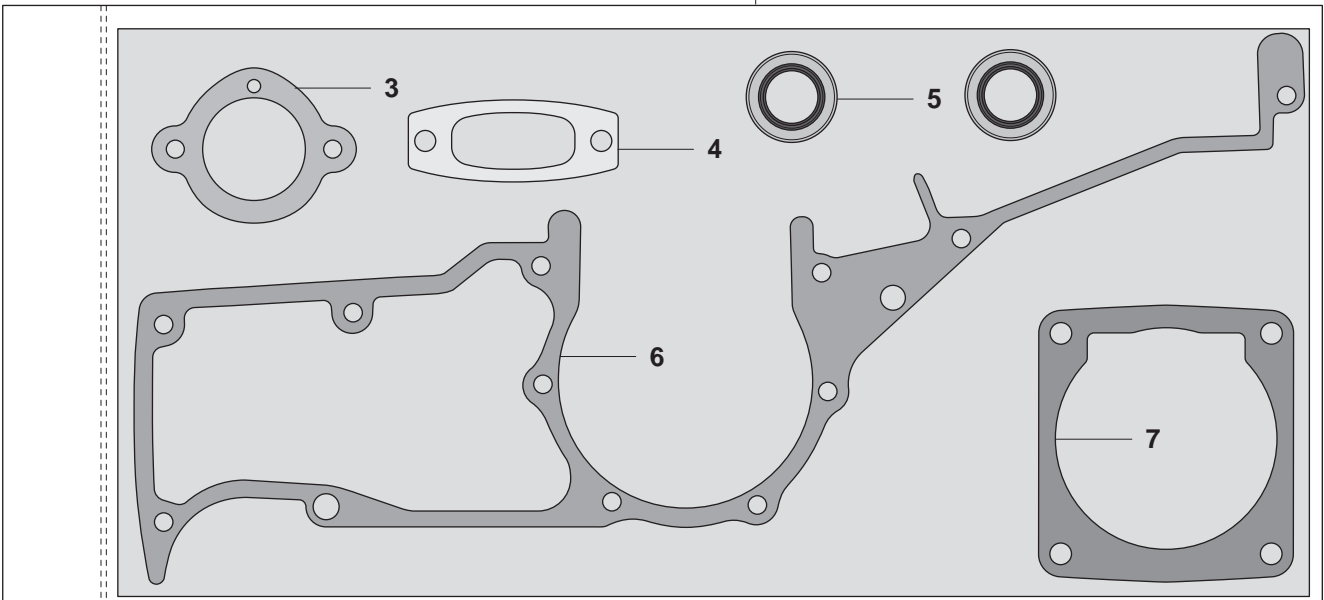
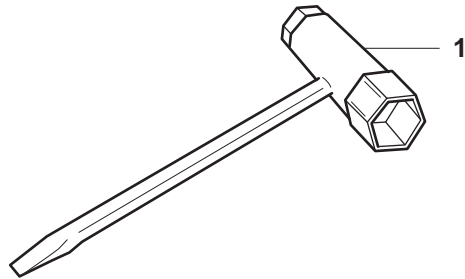

Page P
K1250, K1250 Rail

Pos.	Part No.	Description	Quantity	Notes	New Part
1	501 69 17-02	COMBINATION TOOL	1		
2	506 29 24-02	GASKET KIT	1		
3	506 27 43-01	GASKET	1		
4	503 13 13-04	GASKET MUFFLER	1		
5	503 26 02-05	SEALING RING	2		
6	503 13 45-01	CRANKCASE GASKET	1		
7	503 13 46-01	GASKET	1		

Q K1250
K1250 Rail

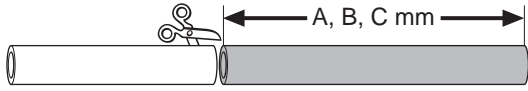
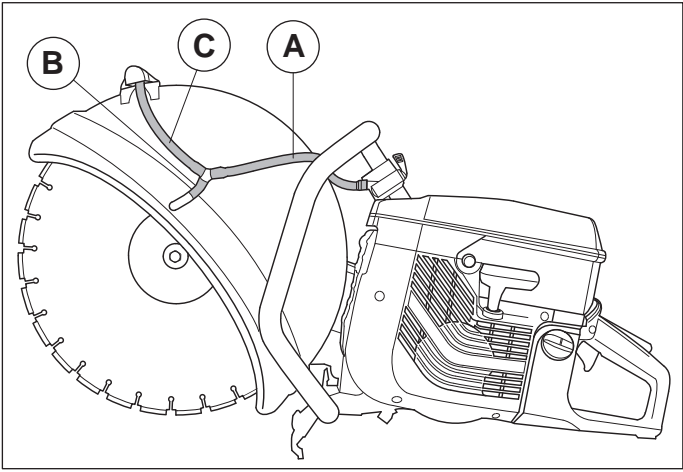
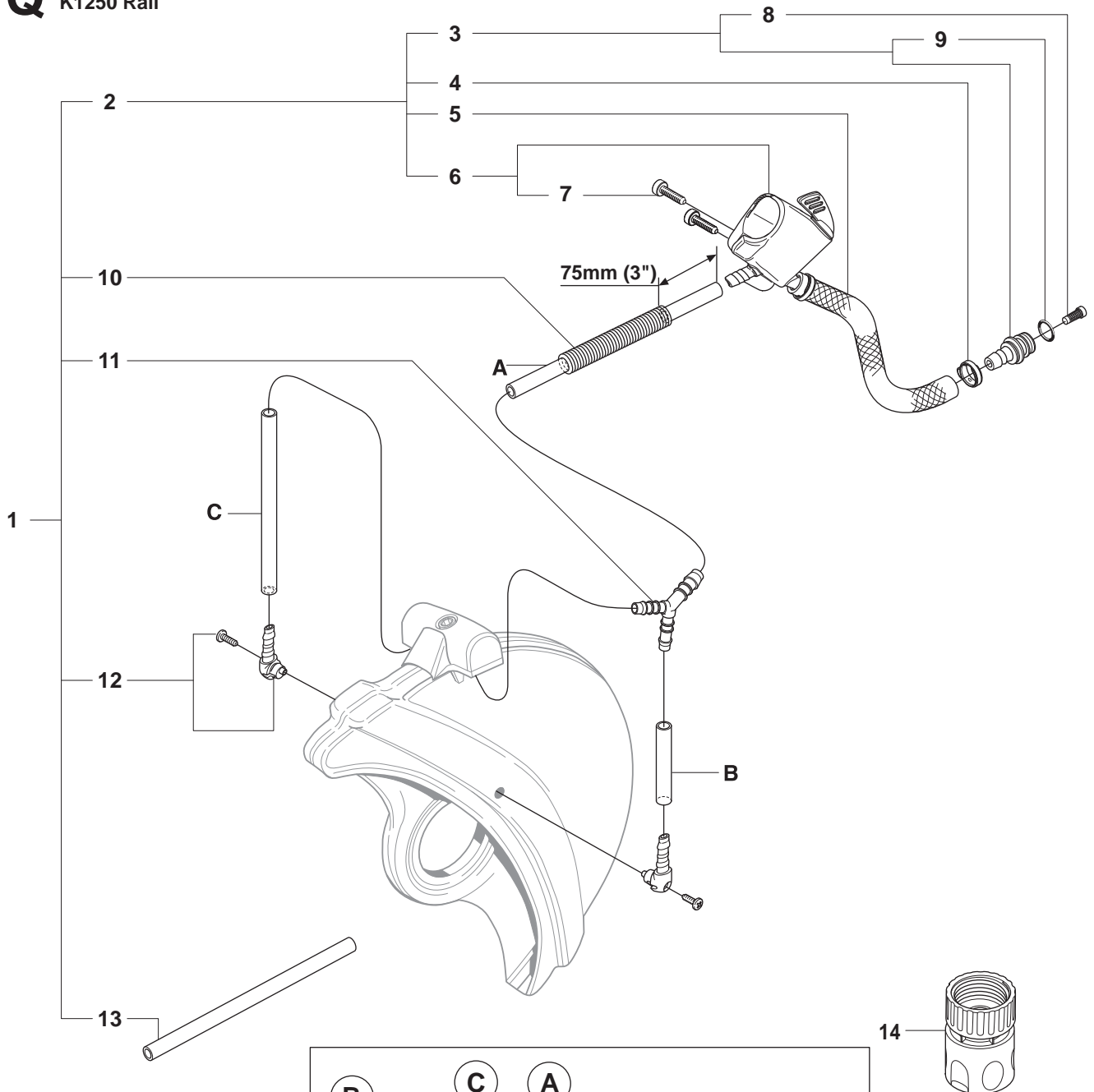

Product		A (mm)	B (mm)	C (mm)
K1250A	14"	280	45	280
	16"	270	45	360

Page Q**K1250, K1250 Rail**

Pos.	Part No.	Description	Quantity	Notes	New Part
1	544 00 31-03	WATER HOSE KIT	1	Incl, 2, 10-13	
2	506 32 90-21	HOSE	1	Incl. 3-6	
3	506 29 57-02	NIPPLE	1	Incl. 8	
4	506 09 56-02	HOSE CLAMP	2		
5	506 09 75-02	HOSE	1	L=230mm	
6	506 31 77-31	VALVE ASSY	1	Incl. 7	
7	503 21 06-19	SCREW	2		
8	506 29 88-01	FILTER	1		
9	503 26 30-21	O-RING	1		
10	506 35 27-01	PROTECTIVE SPRING	1		
11	506 32 87-01	Y-TUBE	1		
12	506 29 56-01	NIPPLE	2		
13	506 09 58-24	HOSE	1	L=800mm	
14	503 26 60-02	COUPLER	1		

R K1250
K1250 Rail

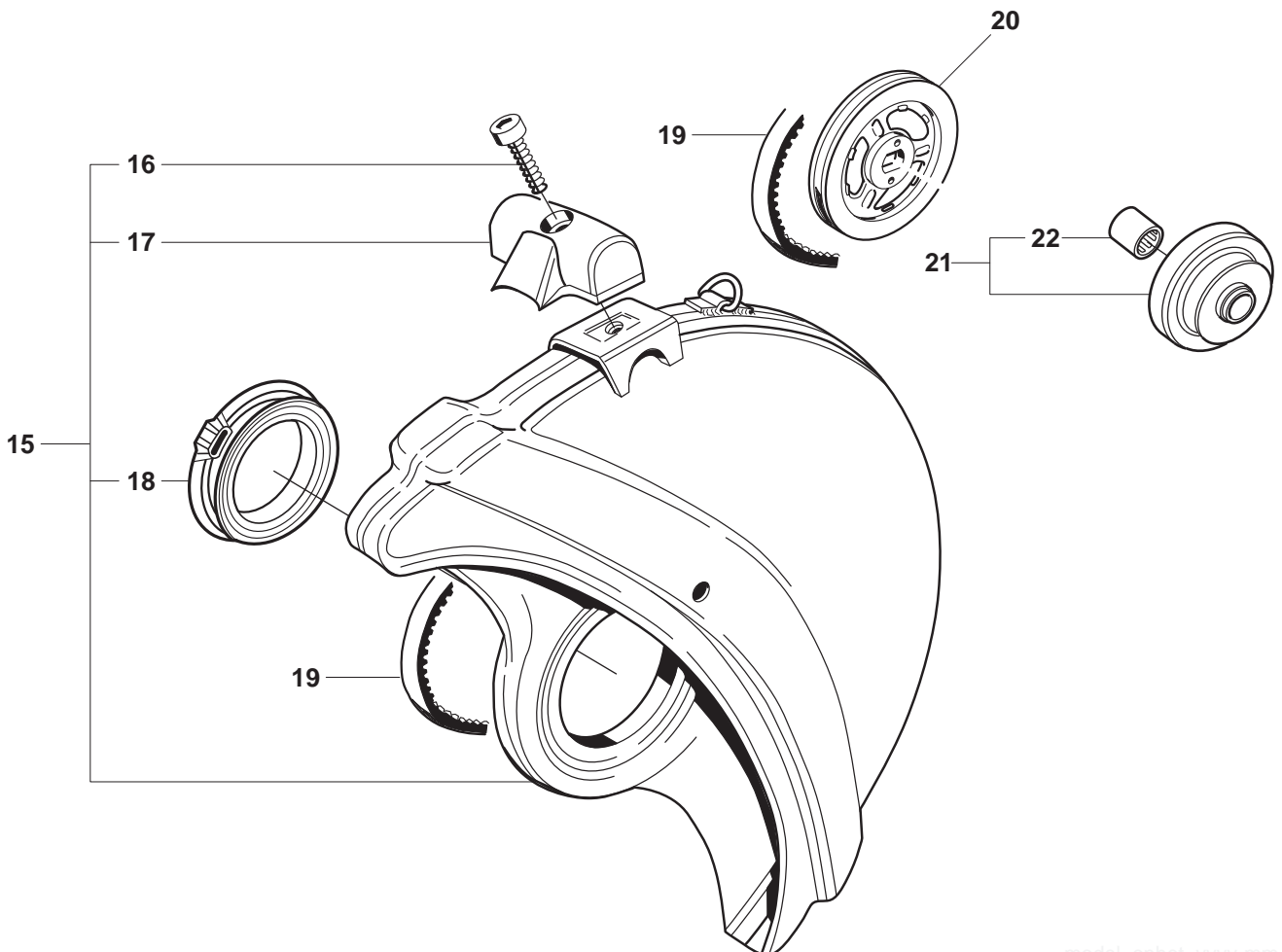
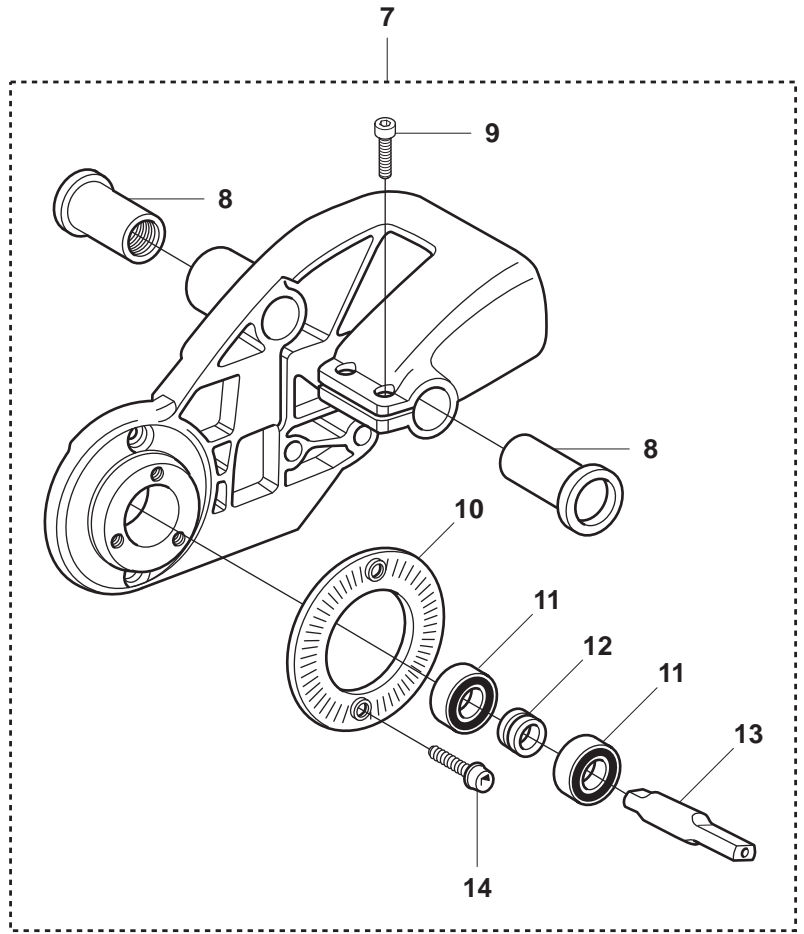
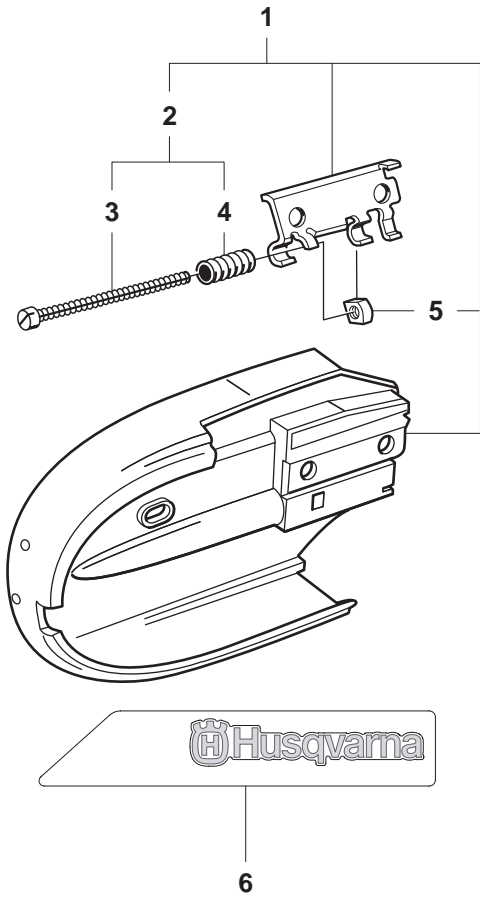

Page R**K1250, K1250 Rail**

Pos.	Part No.	Description	Quantity	Notes	New Part
1	506 27 92-03	BELT GUARD	1	Rail 14", Incl. 2, 5	New Part
1	506 27 92-04	BELT GUARD	1	Rail 16", Incl. 2, 5	New Part
2	506 26 66-03	BELT TENSIONER ASSY	1	Incl. 3, 4	
3	503 20 30-11	SCREW	1		
4	506 26 68-01	COMPRESSION SPRING	1		
5	503 22 66-01	NUT	1		
6	544 87 36-01	LABEL	1		
7	544 88 75-01	BEARING HOUSING	1	Rail 14", Incl. 8 - 14	New Part
7	544 88 75-03	BEARING HOUSING	1	Rail 16", Incl. 8 - 14	New Part
7	544 88 75-05	BEARING HOUSING	1	Rail 16" USA, Incl. 8 - 14	New Part
8	506 22 75-01	SLEEVE	2		
9	503 20 02-16	SCREW	2		
10	506 28 84-01	SCREEN PATTERN FLANG	1		
11	503 25 21-01	BALL BEARING	2		
14	503 20 07-12	SCREW	2		
12	506 07 08-01	SPACING SLEEVE	1		
13	506 29 83-63	SHAFT	1		
15	506 34 05-24	WHEEL GUARD ASSY	1	Rail 14", Incl. 16 - 18	
15	506 34 05-26	WHEEL GUARD ASSY	1	Rail 16", Incl. 16 - 18	
16	725 53 31-55	SCREW	1		
17	506 34 46-02	HANDLE	1		
18	506 26 63-02	LINING	1		
19	506 37 27-21	BELT	1	Rail 14"	
19	506 37 27-28	BELT	1	Rail 16"	
20	506 07 18-02	PULLEY	1		
21	506 25 49-01	GEAR WHEEL ASSY	1	Rail 16". Diam 41 mm. Incl. 22	
21	506 25 49-03	GEAR WHEEL ASSY	1	Rail 14". Diam 50 mm. Incl. 22	
22	503 25 38-01	NEEDLE BEARING	1		

S K1250
K1250 Rail

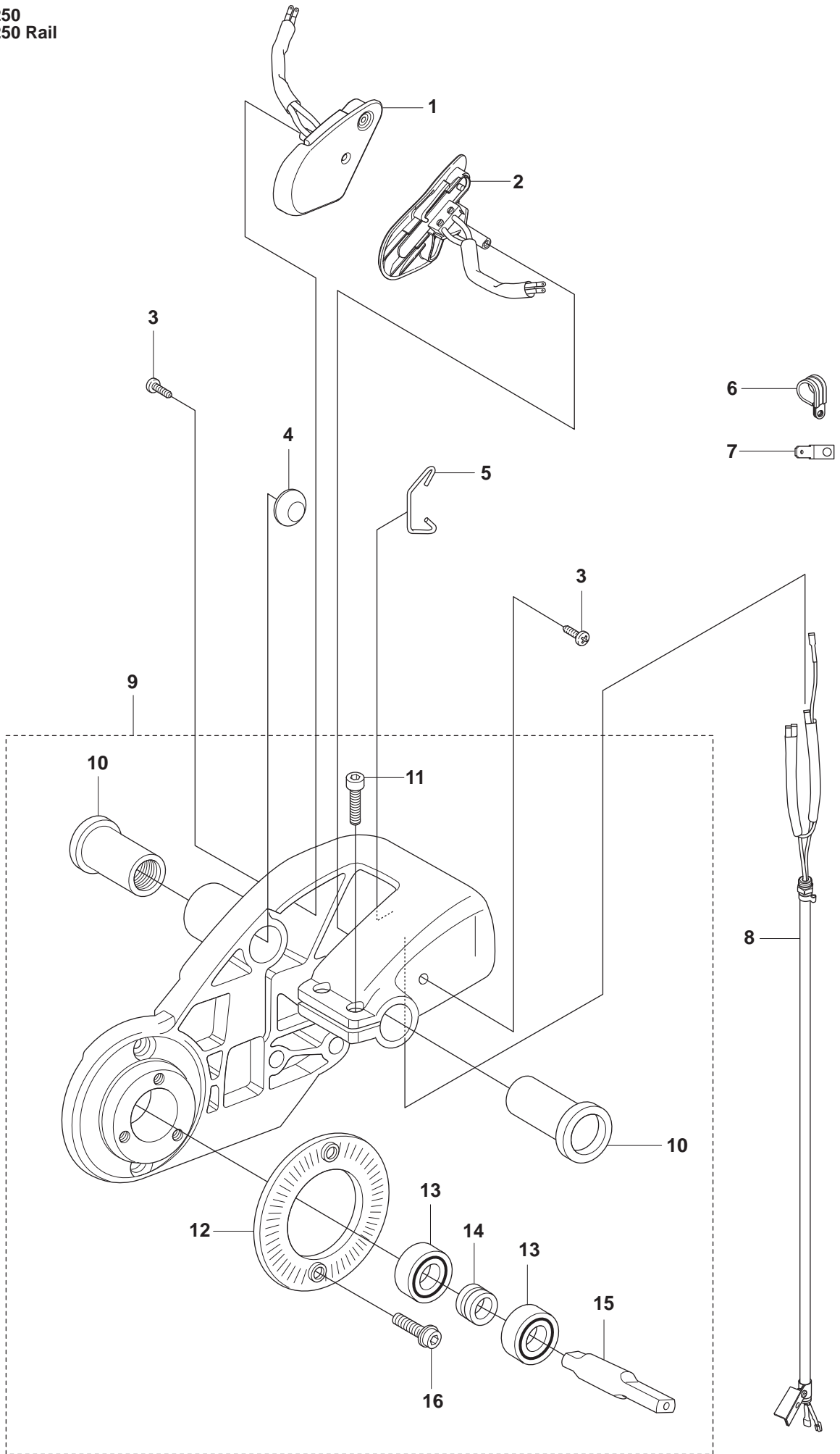

Page S**K1250, K1250 Rail**

Pos.	Part No.	Description	Quantity	Notes	New Part
1	506 35 91-04	STOP SWITCH	1	RH	New Part
2	506 35 91-03	STOP SWITCH	1	LH	New Part
3	729 53 27-71	SCREW	2		
4	506 35 96-01	SPACING BLOCK	1		
6	506 35 80-01	BRACKET	1		
7	535 03 94-01	CONNECTION PLATE	1		
8	506 35 90-01	WIRING	1		
9	544 88 75-02	BEARING HOUSING	1	K1250 Rail 14", Stop, Incl. 10 - 16	New Part
9	544 88 75-04	BEARING HOUSING	1	K1250 Rail 16", Stop, Incl. 10 - 16	New Part
10	506 22 75-01	SLEEVE	2		
11	503 20 02-16	SCREW	2		
12	506 28 84-01	SCREEN PATTERN FLANG	1		
13	503 25 21-01	BALL BEARING	2		
14	506 07 08-01	SPACING SLEEVE	1		
15	506 29 83-63	SHAFT	1		
16	503 20 07-12	SCREW	2		

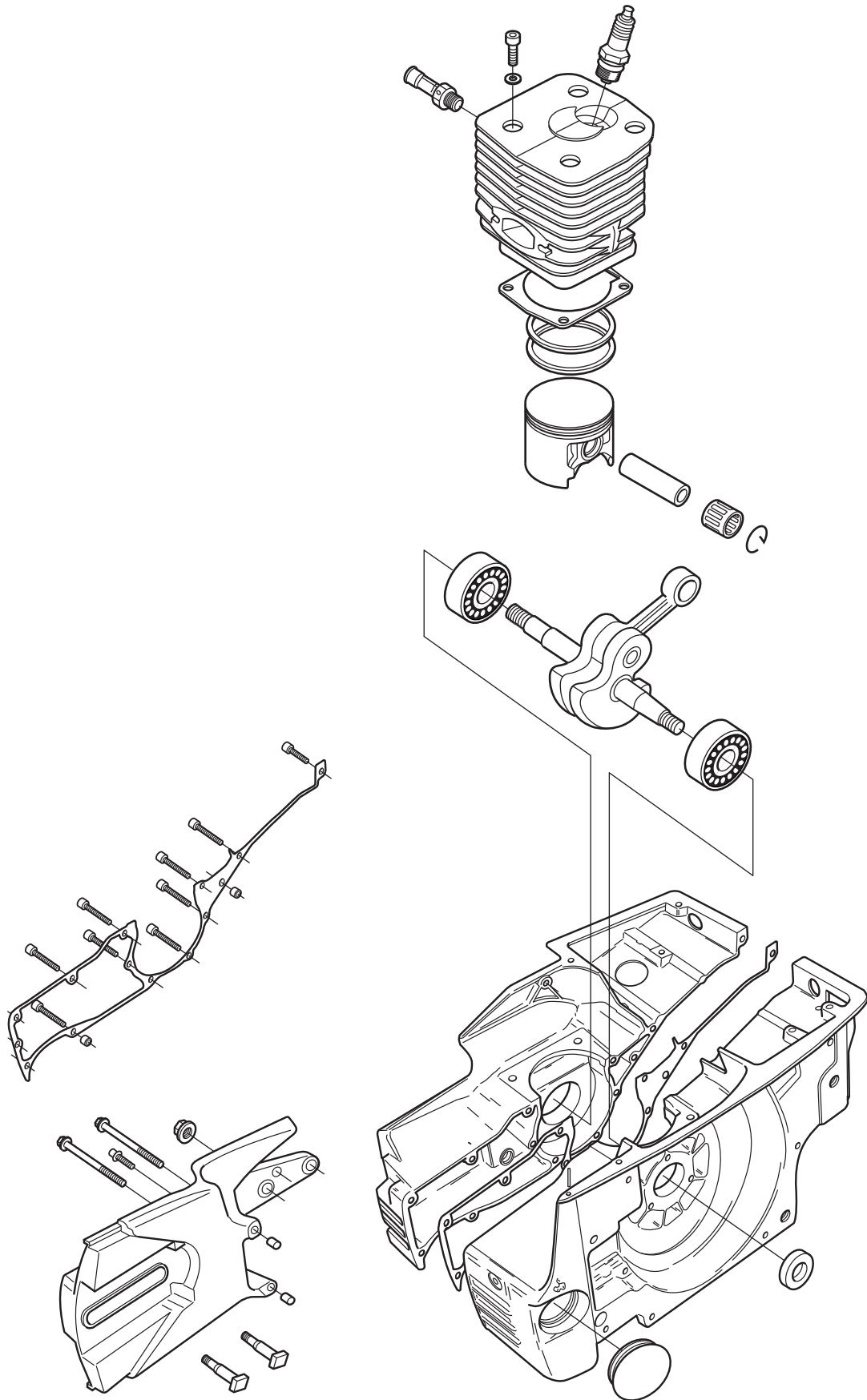

Page T
K1250, K1250 Rail

Pos.	Part No.	Description	Quantity	Notes	New Part
1	544 90 44-03	SHORT BLOCK	1		